

Short Report on the Design of a TEM-Stripline

December 4, 2008

The structure examined is shown in Fig. 1. The dimensions are as follows: septum length 20 m, septum width 3.5 m, septum height 5 m. The apexes of the stripline form an angle of about 60° with the horizontal plane.

Some approximations are used: the ground plane and the stripline are composed of perfect electric conductor (PEC) material; no impedance adaptor has been introduced between the source generator and the stripline.

The stripline is fed with an input power of 1000 W.

In Figs. 2 and 3 the amplitude of the electric field calculated at three points (0;0.5;0), (0;2.5;0), (0;4.5;0) is shown. The field uniformity of 0-6 dBV/m is satisfied.

In Figs. 4-6 the amplitude of the electric field in a section of the stripline ($z=0$) at three different frequencies (0.1, 3 and 30 MHz) is shown. The field uniformity of 0-6 dBV/m is satisfied.

In Fig. 7 the electric field amplitude calculation for an input power of 2000 W is shown. The calculation refers to the same point as per Fig. 2. The requested amplitude of 36 V/m seems to be obtained at 2.5 m of height.

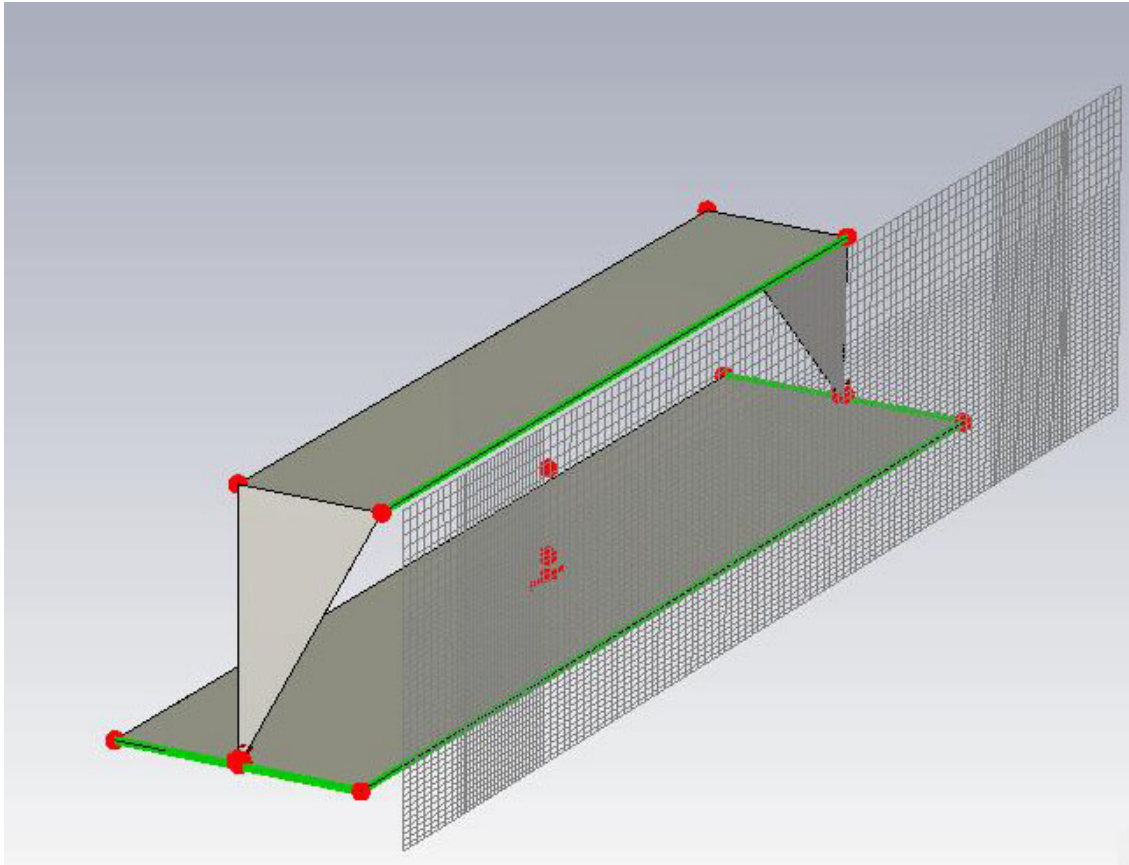

Figure 1: Model of the TEM-Stripline

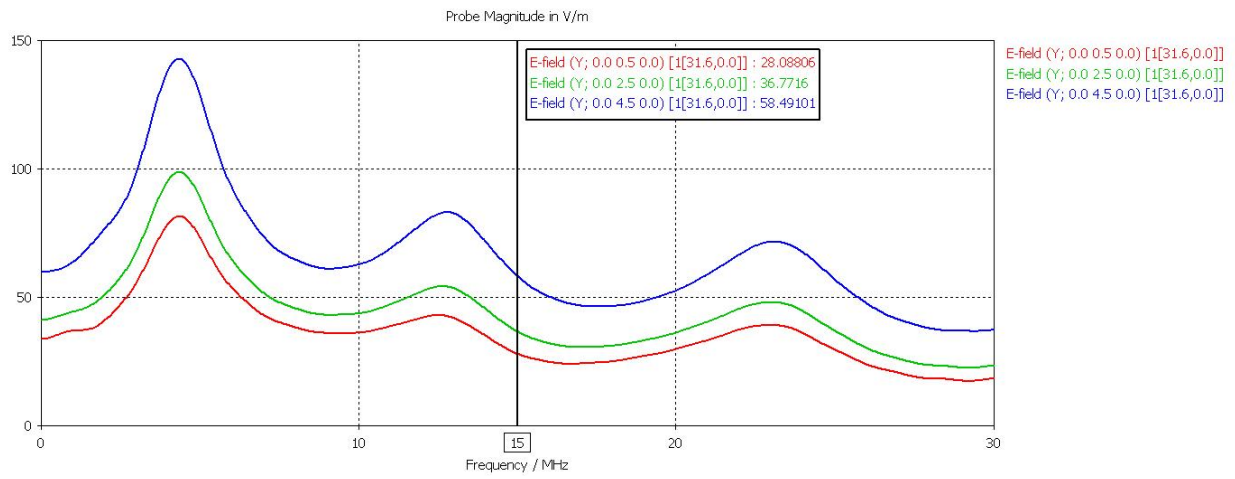

Figure 2: Electric field in V/m at three points.

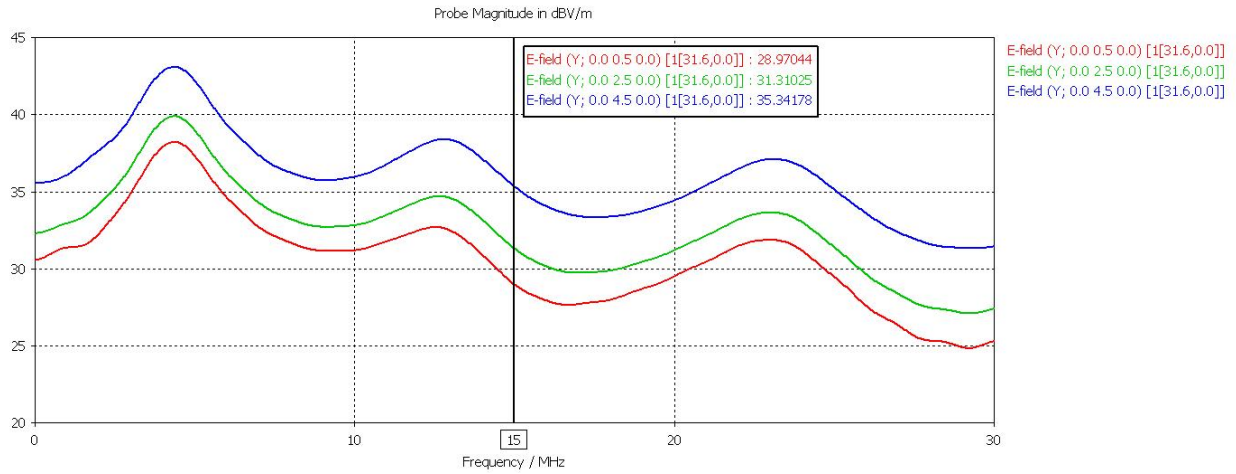

Figure 3: Electric field in dBV/m at three points.

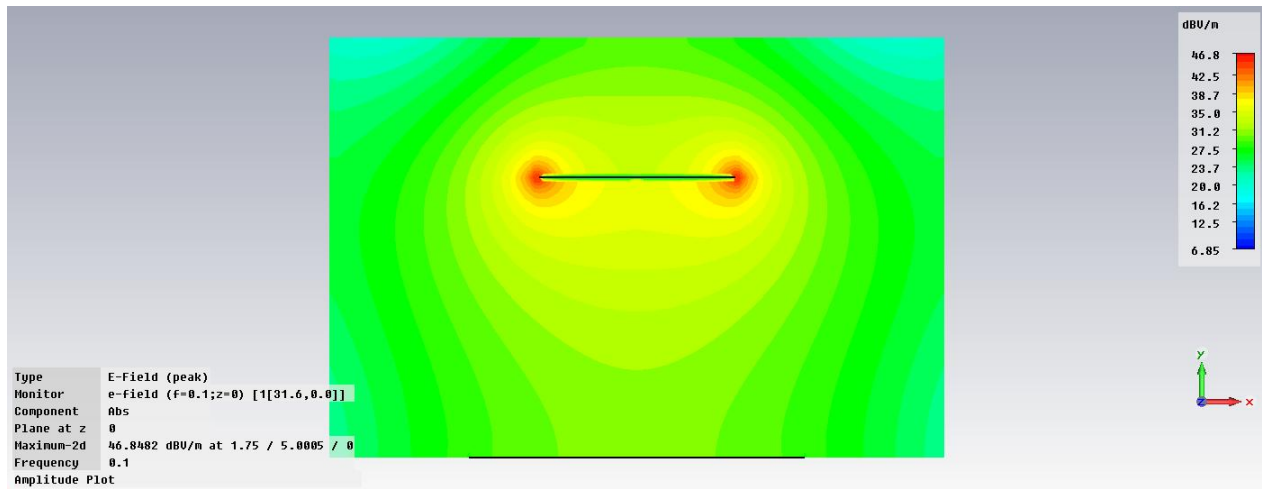

Figure 4: Electric field amplitude in the section $z=0$ of the stripline at 100 kHz.

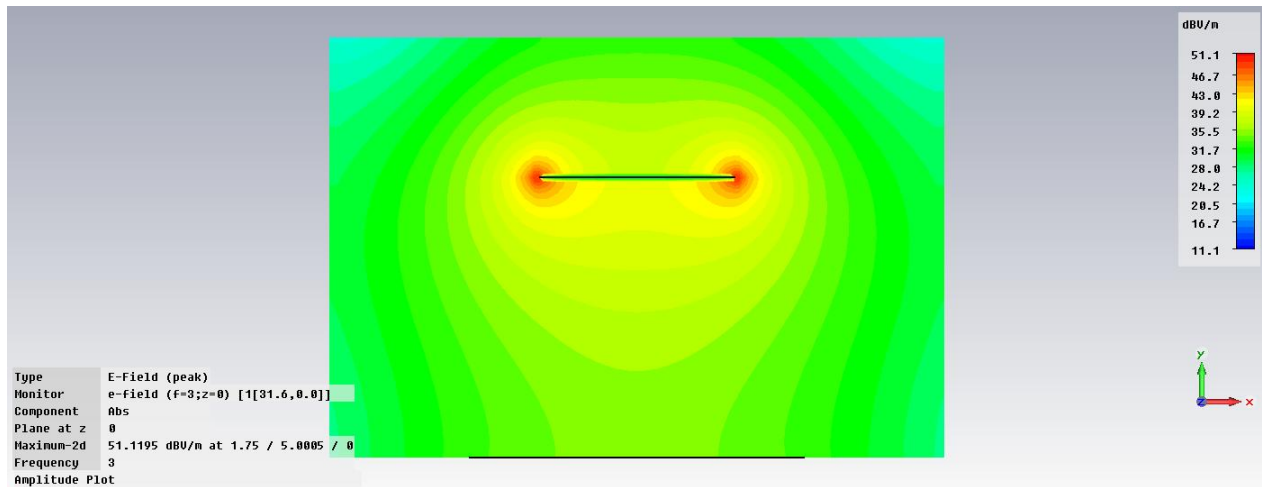

Figure 5: Electric field amplitude in the section $z=0$ of the stripline at 3 MHz.

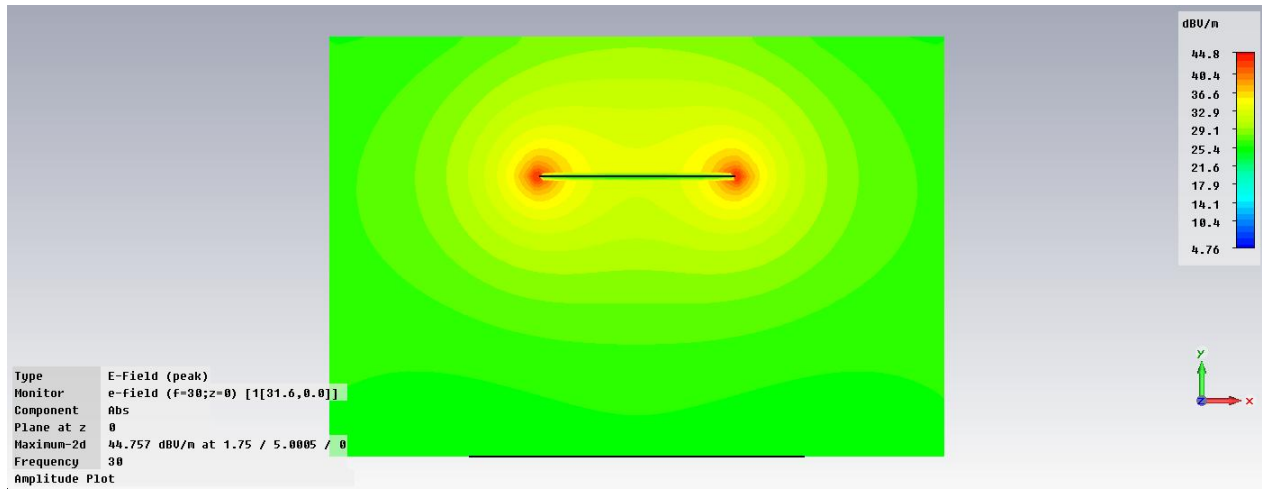

Figure 6: Electric field amplitude in the section $z=0$ of the stripline at 30 MHz.

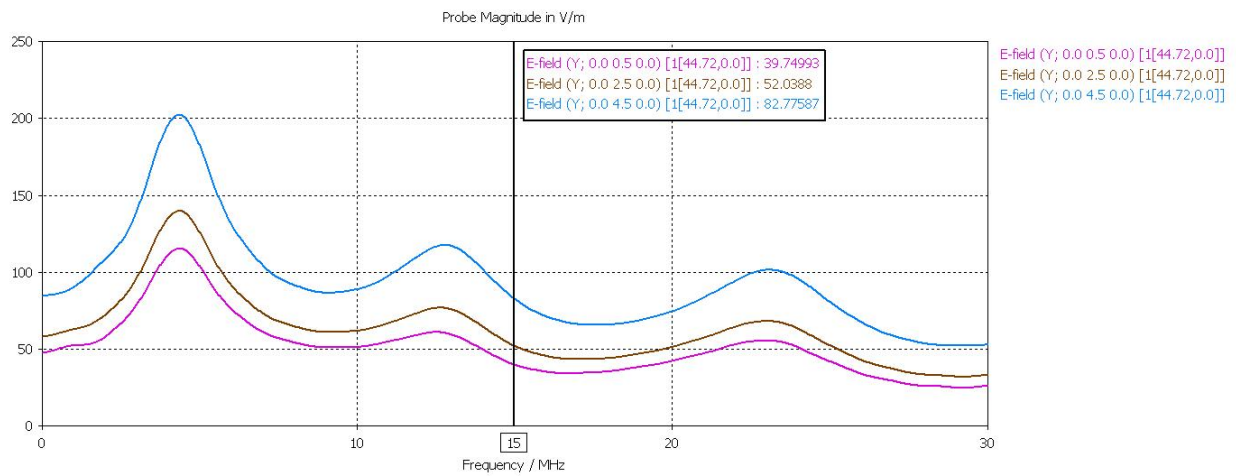

Figure 7: Electric field amplitude for an input power of 2000 W.